

# Planetary Gearcase Rebuild

**Bucyrus & Marion Machines**

*(USA Market Only)*

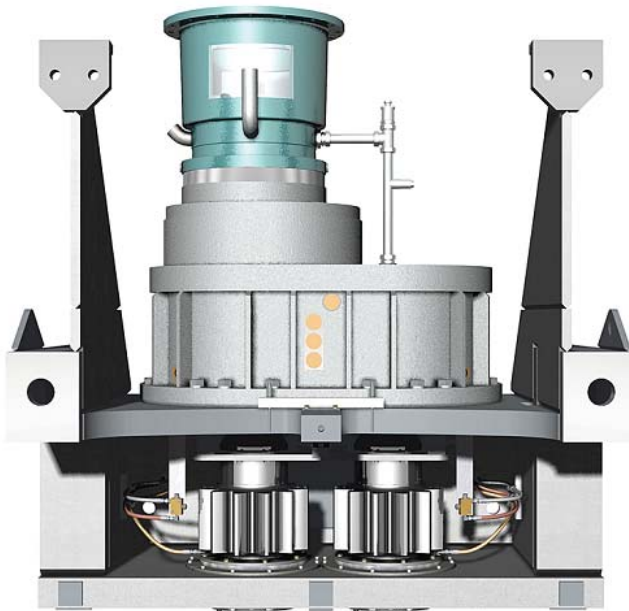

## **Applicable Gearcases:**

Shovel Planetary Propels: 395BIII, 495, 301M, 351M, 595B

Shovel Planetary Swings: 495, 301M, 351M, 595B

Shovel Planetary Hoist: 495, 301M, 351M, 595B

Shovel Planetary Crowd: 301M, 351M, 595B

Drill Planetary Propel: 49R, 59R

Dragline Planetary Swings: 8200, 8750, 2570WS.

## **Benefits**

- Bucyrus' rebuild program assists with extending the active life of our customers' gearcases through proactive maintenance and service. This proactive approach ensures that wear components are replaced prior to gearcase failure or irreversible damage to major parts. Planning the work in advance supports quicker rebuild turnaround time.
- Bucyrus offers complete gearcase inspections and failure analyses by fully trained technicians to determine the condition of the gearcase and provide a total cost of repairing the unit within the rebuild program.
- Following the disassembly and inspection of the gearcase, Bucyrus provides our customers with a full report including images of damaged components, allowing the customer to decide whether or not to proceed with the recommended scope of work.
- Bucyrus implements the latest technical specifications, designs and service parts, as well as applicable product improvements in all gearcase rebuilds.
- Bucyrus provides a 12-month warranty on labor and replacement parts for our gearcase rebuilds.

## **Why Bucyrus?**

Our goal is to do everything we can to meet your expectations of quality, value and reliability to enhance your performance and bottom line. We rely on your day-to-day assessment of our performance to improve our ability to support you.

**BUCYRUS INTERNATIONAL, INC.** For more information, contact your local Bucyrus sales representative or our corporate office located at: 1100 Milwaukee Avenue • P.O. Box 500 • South Milwaukee, WI 53172-0500 • 414.768.4000 • FAX 414.768.4474 • An ISO 9001:2000 registered firm.